

1

2

3

4

5

REVISION TABLE

REV	ECN#	DESCRIPTION	REV BY	APPROVED	DATE
---	---	Original Drawing	OOG	MPW	8-1-10

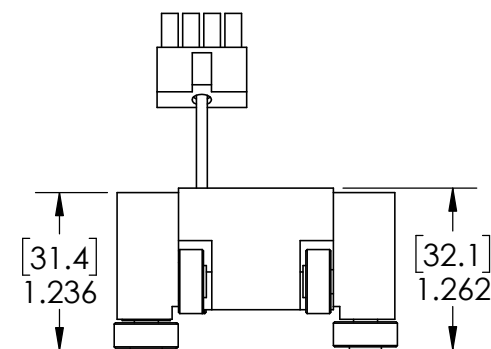
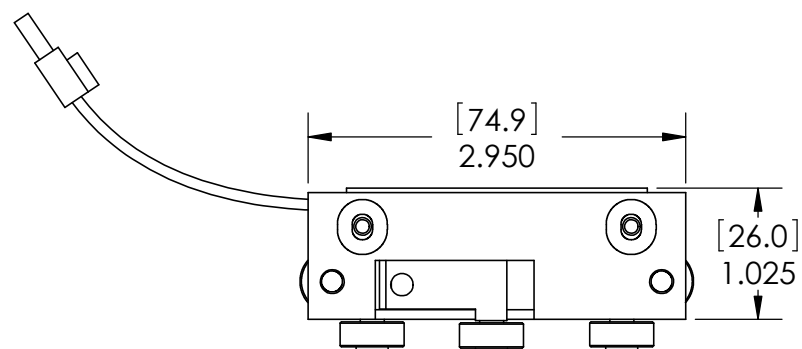
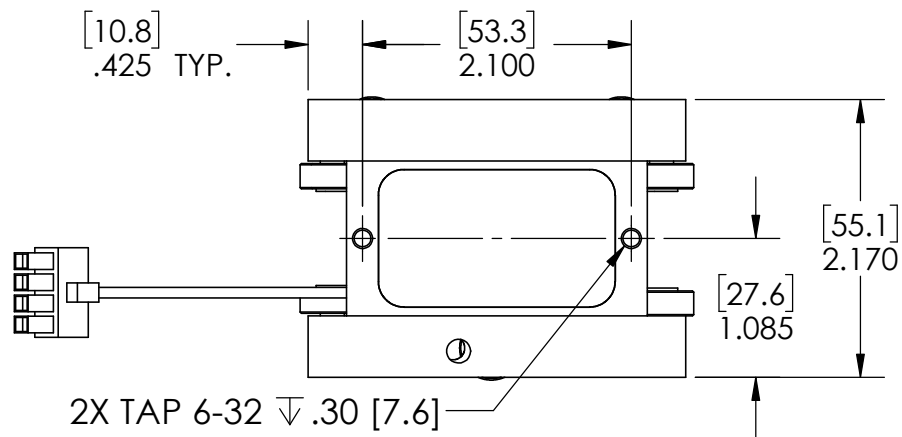

H2W Technologies, Inc.
 Santa Clarita, CA 91350 USA
 Tel: (661) 291-1620
www.h2wtech.com

These drawings and specifications are the property of H2W Technologies, Inc. They are issued in confidence and shall not be reproduced, copied, or used without written permission from H2W Technologies, Inc.

UNLESS SPECIFIED OTHERWISE:
 All dimensions are in inches
 Standard Tolerances are as follows
 .XXX ±.005 ANGLES ±.1°
 .XX ±.010 FILLETS .010
 .X ±.020 CORNERS .010
 Remove All Burrs and Sharp Edges

**FOR
 REFERENCE
 ONLY**

MATERIAL

FINISH

TITLE

Single Axis Stepper Model #:
STS-0213-R

DWG # **10-0463**

REV ----

DATE 8-1-10 SHEET 1 of 4

COMPATIBLE PLATEN SPECIFICATIONS

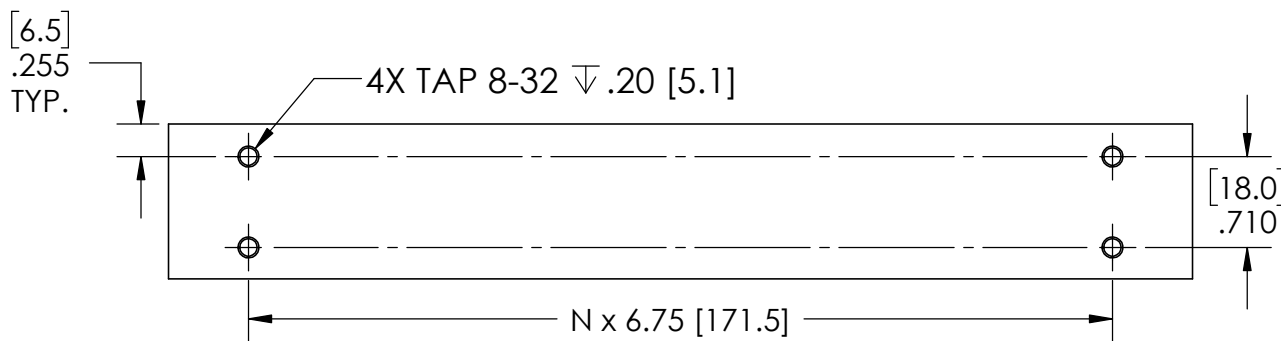
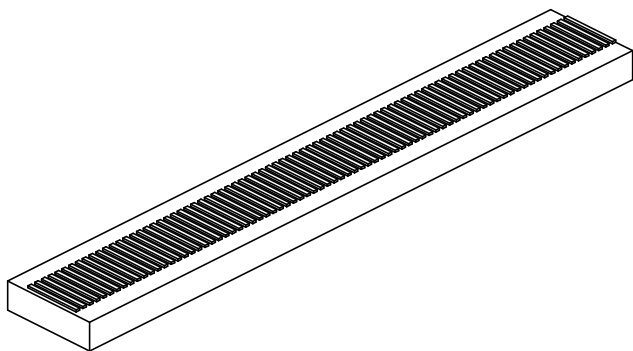
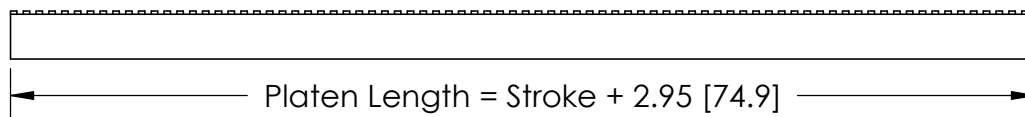
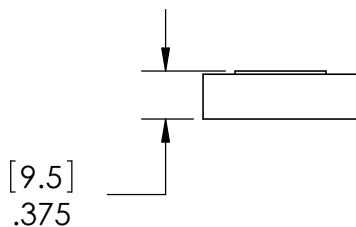
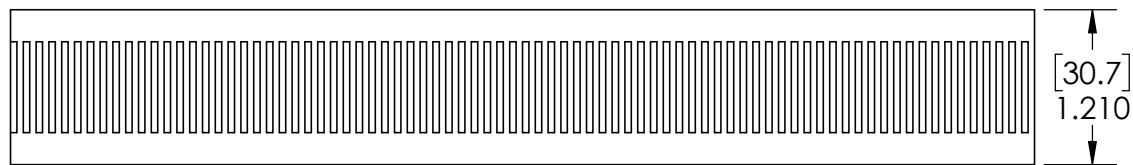

Platen Model #: STP-13-XXX-R



H2W Technologies, Inc.
 Santa Clarita, CA 91350 USA
 Tel: (661) 291-1620
www.h2wtech.com

These drawings and specifications are the property of H2W Technologies, Inc. They are issued in confidence and shall not be reproduced, copied, or used without written permission from H2W Technologies, Inc.

UNLESS SPECIFIED OTHERWISE:
 All dimensions are in inches
 Standard Tolerances are as follows
 .XXX ±.005 ANGLES ±.1°
 .XX ±.010 FILLETS .010
 .X ±.020 CORNERS .010
 Remove All Burrs and Sharp Edges

**FOR
 REFERENCE
 ONLY**

MATERIAL
 FINISH

TITLE
 Single Axis Stepper Model #:
STS-0213-R

DWG # **10-0463**
 REV ----
 DATE 8-1-10 SHEET 2 of 4

1

2

3

4

5

MOTOR SHOWN MOUNTED ON PLATEN

A

A

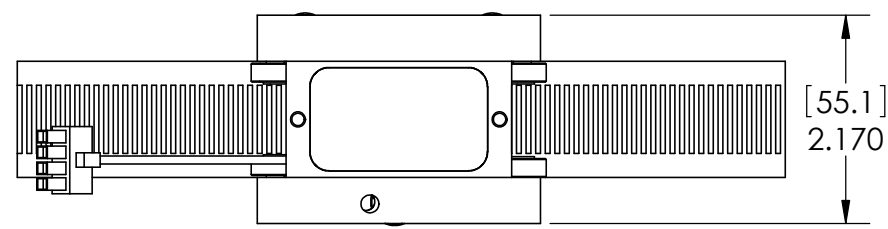

B

B

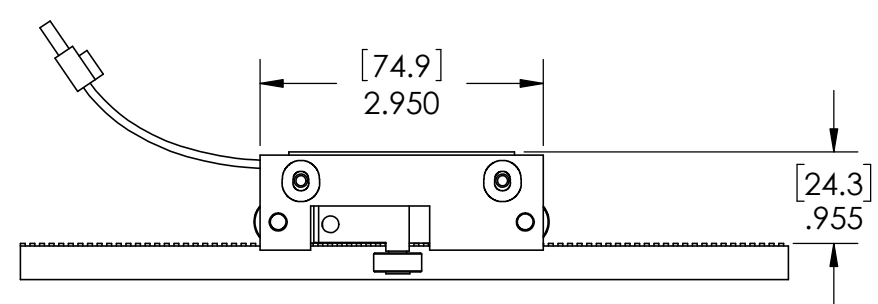
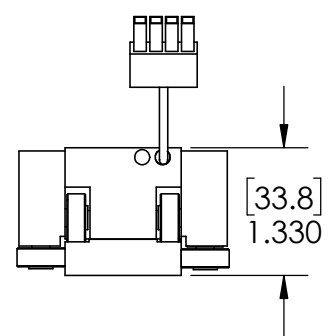

C

C

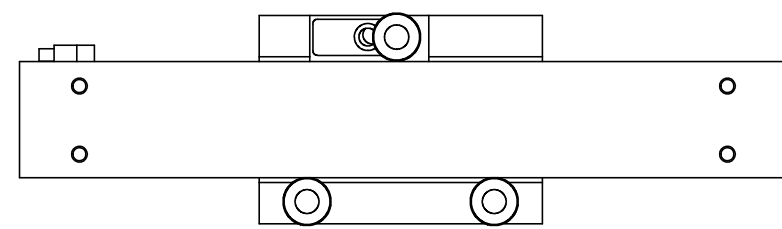
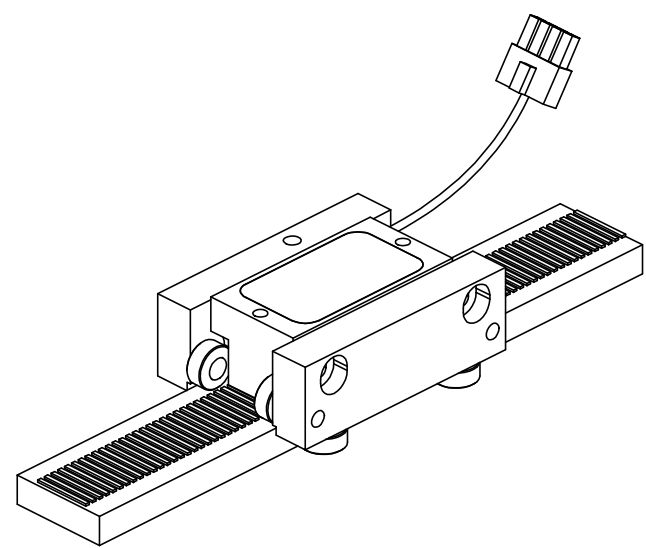

D

D

1

2

3

4

5

LINEAR STEPPER MOTOR SPECIFICATIONS

Motor P/N	STS-0213-R	
Continuous Force	2.30 LBS	10.22 N
Rated Current	2.0 Amp	
Resistance/Phase @ 20C	1.65 ohms	
Inductance/Phase @ 20C	1.75 mH	
Motor Phases	2	
Bearing Type	Roller Bearing	
Nominal Airgap	0.0015"	
Motor Mass	8.1 oz	230 grams

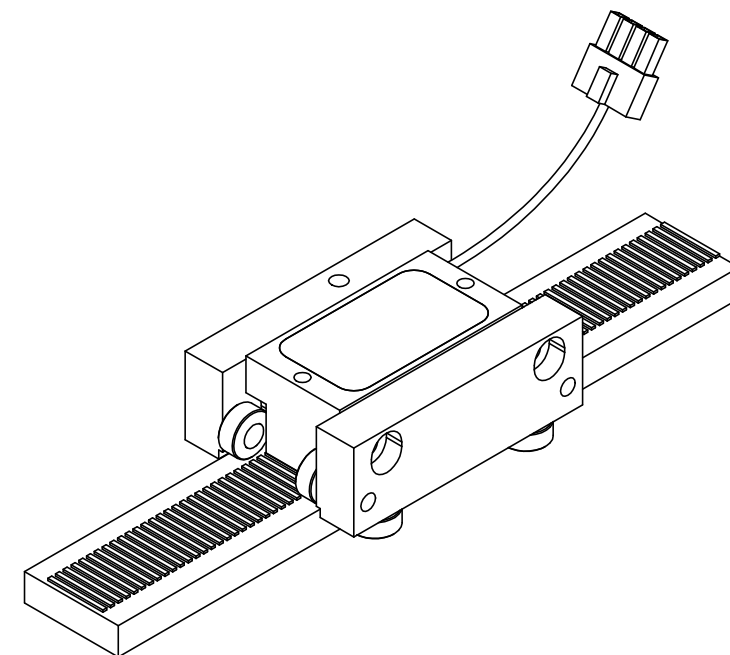
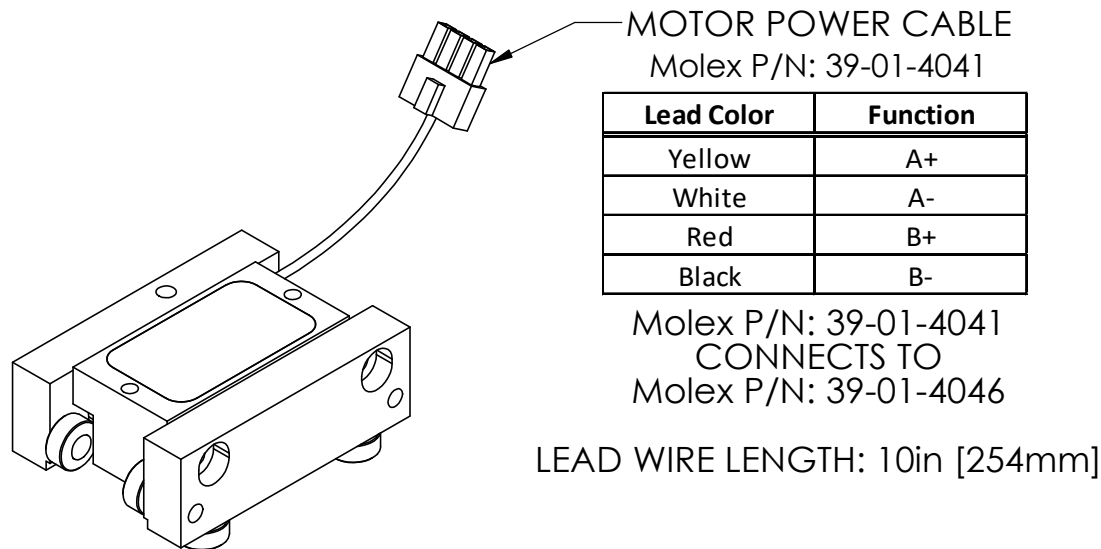

H2W Technologies, Inc.
Santa Clarita, CA 91350 USA
Tel: (661) 291-1620
www.h2wtech.com

These drawings and specifications are the property of H2W Technologies, Inc. They are issued in confidence and shall not be reproduced, copied, or used without written permission from H2W Technologies, Inc.

UNLESS SPECIFIED OTHERWISE:
All dimensions are in inches
Standard Tolerances are as follows
.XXX ±.005 ANGLES ±.1°
.XX ±.010 FILLETS .010
.X ±.020 CORNERS .010
Remove All Burrs and Sharp Edges

**FOR
REFERENCE
ONLY**

MATERIAL

FINISH

TITLE

Single Axis Stepper Model #:
STS-0213-R

DWG # **10-0463**

REV

DATE

8-1-10

SHEET

4 of 4